

## Parts List and Exploded View

### Support Frame ASSY

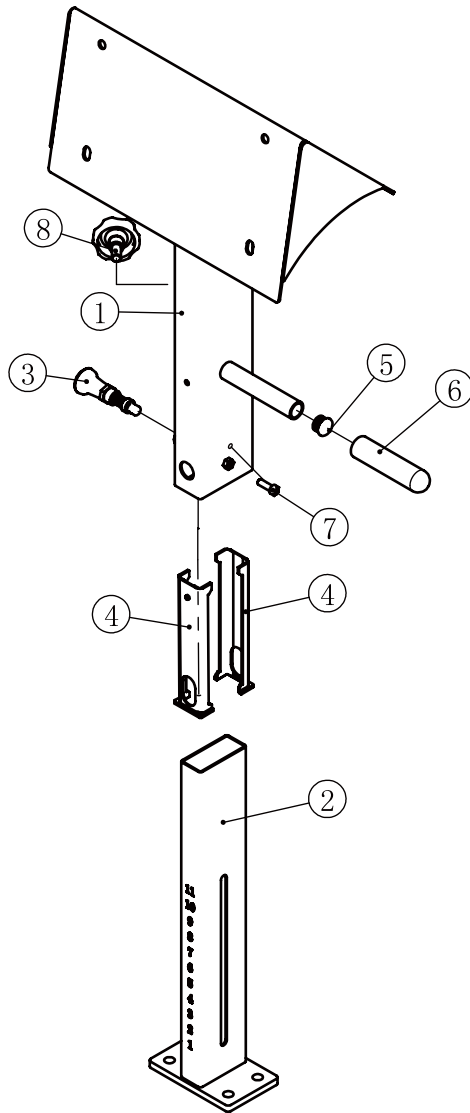

Item No.	Grade No.	Part No.	Description	QTY
1	4.1	SL701 80500	Support Frame	1
2	4.2	SL701 80400	Adjustable Support	1
3	4.3	IT9322G0500	Pull Pin	1
4	4.4	SL70473100	Plastic Tube Guide	2
5	4.5	HF405A0700	End Plug	1
6	4.6	BNH0523	Grip	1
7	4.7	GB70M8*25DHS20	Socket Head Cap Screw M8*25	1
8	4.8	PBD10301Y	Lock knob	1

## Exercise Instructions and Adjust Instructions

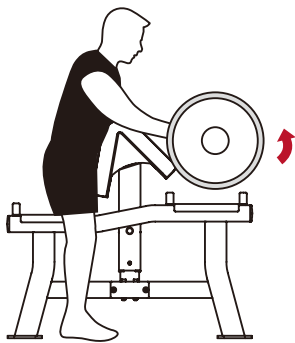

**Start**

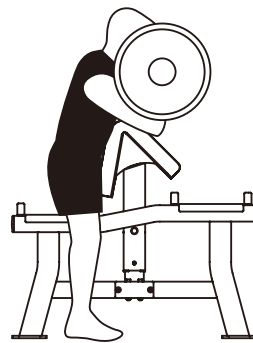

**Finish**

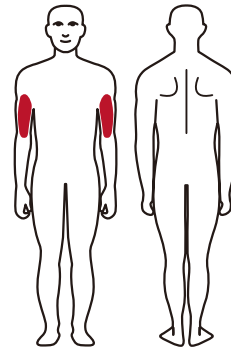

### Exercise Instructions

1. Adjust Arm pad to the desired position.
2. Do preacher curl with barbell.
3. The total weight can not be greater than 200kg.
4. This equipment does not contains Barbell and Weight Plate.

### Arm Pad adjustment

1. Pull the Pull pin and adjust the Arm Pad to the desired position.
2. Make sure that the pin gets into the hole completely.
3. Lock the Lock knob.

